



Low Cost frequency Jamming circuits for AM and FM radio Systems in local Pakistani Environment

M. T. MUSHTAQ, M.S. KHAN*, F. A. MEMON**, M.S. KHAN***, T. IQBA****

Department of Electrical Engineering, (UET), Lahore

Received 8th March 2014 and Revised 23th September 2014

Abstract: In Pakistan criminals are using different radio systems to convey their hatred messages. It is necessary to stop the propagation of their propaganda by using low cost jamming solutions. For security purposes, various frequency jamming techniques were supposed to be implemented to disturb the radio communication, cell phone, radar and wireless transmission signals. In this research work, these techniques are discussed and low cost solutions are provided to jam the illegal amplitude modulation (AM) and Frequency modulation (FM) based radio systems in laboratory environment. These circuits were implemented with the help of discrete components and integrated circuit (ICS). The power of the purposed system is less than commercially available jammers. The Electronic Workbench (EWB) software and MS Visio were used during the designing process.

Keywords: Amplitude modulation, Frequency modulation, Interference, Jamming, Electromagnetic spectrum, Voltage Controlled Oscillator (VCO)

1. INTRODUCTION

The laws of electromagnetic were defined by Maxwell's equations. Hertz work on the antenna theory. The radio was invented by Marconi in (1883). The scientists and engineers are working on the development and improvement of the radio communications. The radio communication is used for military purposes, disaster management, and entertainment and many other purposes. The frequency range of the radio waves lie in between 3000 Hz-30 GHz (10 cm up to 10 Km wavelength) (Ulaby, 2006).

The AM radios are working in the range of 3-30MHz frequency. They can be single side band (SSB) or double side band (DSB) or Vestigle Side bands (VSB). The AM radios need more power for communication. The radio communication systems are developed a lot but the AM radios are still used for long range communication. The Submarine communications are using A.M radio systems.

FM radio systems are short range and need less power. They are normally used for the intercity communication, police communication, and entertainment programs. The FM radios normally communicate in the frequency range of 84-108 MHz.

Criminals are using the illegal FM radios to propagate their hatred message during 2005-2008. In these situations, the law enforcement agencies must have the ability to jamm these illegal communications. The Russia was the first country who used different techniques to jamm the propaganda campaign of the western powers.

In this paper different Low cost jamming circuits are designed with the help of discrete components and IC's. These circuits were operated and checked in electronics Lab of Physics department, GC University, Lahore. The power of the circuit was less than the commercially available jammers. All circuits were implemented in the room environment. The circuits provide the easy to implement, low cost and efficient solution for the said problem. The communication was jammed by generating the AM and FM signals of same commercial frequency. The two different signals of same frequencies generate the constructive and destructive interference. The constructive and destructive Interference is basically responsible for the signal jamming. The jamming can be done for the single frequency or for whole frequency band. The fixed frequency transmitter can be jammed the single frequency and variable frequency transmitter is able to jamm the whole frequency band. The series of transmitters attached with some analog multiplexer can also be used for the jamming of whole AM or FM frequency spectrum. This technique can also be used for the wideband frequency jamming.

The experimental results of the whole research can be summarized as:

1 Special with the help of Transistors (2N-3904) the A-M jammer of 540 KHz was designed which was able to jamm in the range of 6 feet. The F-M jammer was made with the help of same transistor and this circuit effectively jammed in the range of 15 meters.

++Correspondence Author: Email: fiazmemon@usindh.edu.pk

*Computer Science Department, GC University, Lahore

**Institute of Mathematics & Computer Science, University of Sindh, Jamshoro

***Department of Electrical Engineering, University of Gujrat, Jalalpur Jattan road, Gujrat

****D.J Science College, Krachi

2 The AM & FM jamming signals were generated with the help of 74HC04 (NOT gate), 74HC00 (NAND gate) and 4093 (Schmitt triggered NAND gate).

3 The AM Signals were generated with the help of VCO IC NE-566.

4 The generation of the signals having the frequency >100 MHz was designed with the help of frequency multiplier circuits. For the design of oscillators, the class-A amplifiers were used. For the designing of RF amplifier stage the class C amplifiers were found suitable. The antenna and inductors were made with the help of 18, 36, 38 gauge copper wire. Normally the antenna was made by 4 to 6 turns

5 During the Research the component values were checked by “Escort-130, Escort-1341 Digital millimeters and wave shapes were checked by Digital oscilloscope GDS 810.

This paper is divided in to 4 sub sections. In 2nd section, Electromagnetic spectrum is explained, The AM and FM jamming circuit are discussed in section 3. In section 4 the conclusion of the whole research work is drawn.

2. MATERIAL AND METHODS

Electromagnetic Spectrum

The electromagnetic spectrum is defined in 30-300GHz. The whole spectrum is subdivided in to ELF to EHF ranges. The details of the electromagnetic spectrum is given below

Table1: Electromagnetic Spectrum (Ulaby, 2006)

Name	Frequency	Uses
Extremely low frequency (ELF)	30-300Hz	Ac power line
Voice Frequencies (VF)	300-3000Hz	Normal range of human speech
Very low frequencies (VLF)	3-30KHz	Navy communicate with Submarines
Low frequencies (LF)	30-300 KHz	Aeronautical and marine navigations
Medium Frequencies(MF)	.3-3.0MHz	AM radio broadcasting, marine and aeronautical applications
High Frequencies (HF) or Short Waves	3-30 MHz	Two way radio communication, VOA, BBC, amateurs radio communications
Very High Frequencies	30-300 MHz	Mobile radio, marine and Aeronautical communication, FM radio broadcasting, television channels

Ultra high frequencies (UHF)	.3-3GHz	UHF television channels 14 through 67, land mobile communications, cellular telephones, radar navigation, radio amateurs
Super high frequency(SHF)	3-30GHz	Micro waves used for Satellite and Radar communication
Extremely High frequency (EHF)	30-300GHz	Radar and satellite communication
Infrared	>300GHz	TV Remote control units
Visible spectrum	8000A° to 4000A°	Fiber optic communications,

The above table shows the division of electromagnetic spectrum and the applications of various frequencies. The table shows that the electromagnetic spectrum used for radio communication lies in between 3 KHz up to 30 GHZ. According to IEEE, the microwaves spectrum can be represented subdivided in to 30cm up to 1mm wavelengths (Liao). The frequency division is represented in the following (Table-2).

Table2: Microwave frequencies (Liao)

Designation	Frequency in Giga Hertz
HF	.003-----03
VHF	.003-----03
UHF	.3----1.000
L band	1.00---2.00
S band	2.00---4.00
C band	4.00---8.00
X band	8.00---12.00
KU band	12.00---18.00
K band	18.00----27.00
Ka band	27.00---40.00
Millimeter	40.00----300
Sub-millimeter	> 300.00

3. JAMMING CIRCUITS

In this research work AM and FM jamming is done.

3.1 AM Jammer circuits

The amplitude modulation (AM) communication normally lies in the frequency range < 3MHz. In AM modulation scheme, information signal varies the amplitude of the carrier wave. There is no variations in the frequency of the carrier signal (Lathi, 1998). The characteristics of a modulated signal is expressed in the form of modulation index (μ).

The AM jammer circuit made with the help of transistors is given below: (Fig.1).

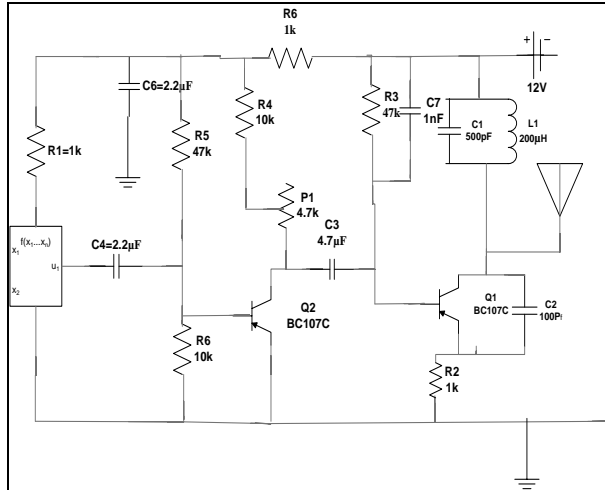

Fig. 1. AM Jammer circuit

The circuit consists of two halves, an audio amplifier and an RF oscillator. The oscillator is built around Q1 and associated components. The tank circuit L1 and VC1 is tunable from about 500 kHz to 1600 KHz. These components can be used from an old MW radio, if available. Q1 needs regenerative feedback to oscillate and this is achieved by connecting the base and collector of Q1 to opposite ends of the tank circuit (Chang, 2000) (<http://www.datasheetcatalog.com/>, n.d.)

The 1nF capacitor C7, couples signals from the base to the top of L1, and C2, 100pF ensures that the oscillation is passed from collector, to the emitter, and via the internal base emitter resistance of the transistor, back to the base again. Resistor R2 has an important role in this circuit. It ensures that the oscillation will not be shunted to ground via the very low internal emitter resistance, r_e of Q1, and also increases the input impedance so that the modulation signal will not be shunted. Oscillation frequency is adjusted with VC1. Q2 is wired as a common emitter amplifier, C5 decoupling the emitter resistor and realizing full gain of this stage. The microphone is an electret-condenser mic and the amount of AM modulation is adjusted with the 4.7kΩ preset resistor P1. In the practical circuit we have used the Function Generator .the Antenna used is made by 6-8 turns of the wire. To increases the Power of the transmitter the Resistance R 7and C5 are removed and emitter of the transistor is directly attached with ground. The circuit Jam the AM communication of the frequency 540 KHZ in a range of 5-6 feet. (Table-3) given below mention the performance of the circuit.

Table 3: The AM Jammer Circuit

C1	V _{out}	I _{out}	Power	frequency
500 µ F	.22 V	4mA	.88 m Watt	40 KHz
1PF	1.2 V	16 mA	19.2m Watt	666.6 KHz

Note. Make an AM circuit with the help of NE 566 VCO using.

3.2 FM Jamming circuits

In the given diagram another FM jammer circuit is given. With the help of this circuit we have Jammed the 92 MHz signal up to 15m. In order to increase the strength of the jammer the R5=100 ohm can be delete and Q1 can be directly grounded (<http://www.datasheetcatalog.com/>, n.d.) (Floyd, 2012) (Boylestad & Nashelsky) (Fig. 2).

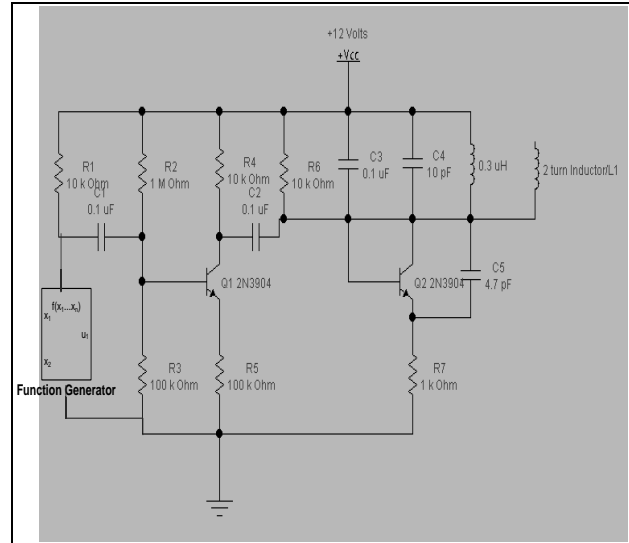

Fig.2. FM jamming Circuit

The experimental results of the FM Jamming circuit are given below in the (Table-4).

Table 4. FM Jammer Circuit parameters

Frequency	V _{out}	I _{out}	Power	Jamming Range
122 MHz	42.42 mV	7.20 mA	.305 4 m watt	10 m
103MHz (R5 is present)	20	.9989 mA	.1996 m watt	6m
103 (R5 is removed)	40	.3984 A	15.936 m watt	15 m

In frequency modulation (FM) the carrier frequency is changed according to modulating signal while the amplitude of the carrier wave is kept constant. The characteristics of FM modulating signal is explained by frequency deviation. While frequency deviation is defined as the amount of change in carrier frequency produced by modulating signal. The major drawback in the designing of FM systems is the intermeditation noise (Stalling, 2002) (Tomasi, 1998) (Lathi, 1998) (Jacob, 2000) (Floyd, 1997) Normally, the carrier frequencies of the FM radio lies in between 88 MHz to 108 MHz and the maximum frequency shift of the

transmitter (during the modulation) is equal to ± 75 kHz. (Stalling, 2002) (Frenzel, 2002) (Tomasi, 1998) (Lathi, 1998) (Schweber, 2002)

3.2.1 Crystal based Voltage Controller FM Jammer Circuit

This type of the circuit was first of all invented by JAφAS (Mr. Shimizu, Silent Key) and JHIFCZ(Mr. Okubo. This VCO use the two Crystal Controlled oscillators of each with 11.0592 MHz frequency. In the experimental setup, the results were.

1. Two 11.0592 MHz X-tals in parallel with 0.1uH inductor and 50pF variable capacitor generate the very stable frequency signals. The transistor used was 2C3905, radio frequency $f_T=2$ GHz.
- (2) Two 11.0592 MHz X-tals in parallel .1 u Henry and + 50pF air variable cap generate the signals in the frequency range 101-106 MHz. The frequency was multiplied by 9.58478 times. The frequency, you might observe a sudden skip of the frequency with hysteresis. This phenomenon can be cured by putting a 10 to 30KΩ resistor in parallel to the inductor (Dai & Harjani, 2000) (Dai, Low Phase Noise Voltage-Control led Oscil ator, 1997) (Chris, 2000) (Wu & Hajimiri, 2000) (A Low Phase Noise VCO Design for PCS Handset Applications)

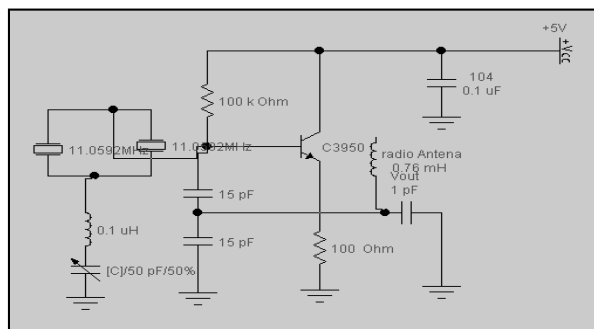

Fig.3. VXCO

Experimental Data.

Wire made open loop antenna was consists of 8 turns its height was 24 cm .The frequency generated and amplitude was not stable. The frequency was generated in the range of 15 MHz up to 109.6 MHz. It was observed that FM signals of 90MHz, 92 MHz, 104 MHz and 110 MHz were jammed in the room range.

The transmitter generated 84MHz-111.51 MHz when an antenna made by 76 m Henry inductor with 22cm height was used. The signal was mainly concentrated around 105-106 MHz frequency. It was observed that FM communication was Jammed effectively in a room range (5 meter) for the frequencies

of 90MHz, 92MHz, 97 MHz, 99 MHz, 100MHz, 101 MHz,103 MHz. It was noted that for the particular 106 MHz frequency, the effective jamming range was almost 50m (at 8 P.m).In this case

The max output voltage =19.2 mv, $I_{out} (max) =4.044612\mu$ amp. Therefore, $P_{out}(max)=77.6565504$ n watt. In this experiment almost whole FM Band was jammed.

3.2.2 FM Jammer circuit by using Sine wave Generator with the Help of 74HC04

The 74HC04 is a high speed CMOS technology based NOT gate. The switching property of the transistor is used here as an Oscillator. The experimental data is given below. At the pin no.4 the output obtained is of the Sine wave (http://www.datasheetcatalog.com/, n.d.) (Floyd., 1997). In the given experiments, the FM signals were jammed in the Lab environment (in the range of 15m).

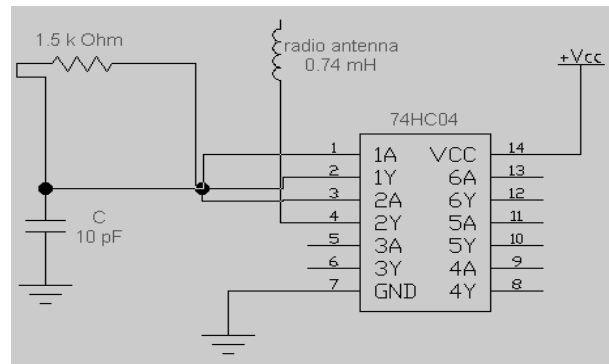

Fig. 4. 7404 based jammer circuit

The experimental data of the 7404 based jamming circuit is given below.

Table 5. Experimental data of 74HC04 based FM jammer circuit

Resistor	capacitor	V _{out}	I _{out} (a.c)	I _{out} (d.c)	power	frequency
1.5 KΩ	10 PF	100 mV	.03 mA	36.2 mA	2.121μ w	63.13 MHz
1.5 KΩ	1 PF	70 mV	16.76 mA	11.8 mA	829.4 μw	106.93 MHz
1 KΩ	1PF	80 mV	62.2μ A	29.6 mA	.181 μw	88 MHz
1 KΩ	1000 PF	1.1 V	.28 μA	.197 μA	.217 μw	9.80 MHz
1 KΩ	2.20 PF	70 mV	118 μA	.0834 mA	5.839 μw	87.72 MHz
1 KΩ	10 PF	.300 V	98 μA	.069 mA	20.785 μw	49.5 MHz
1 KΩ	.50 PF	40 mV	24.3 μA	.017 mA	.687 μw	94.16 MHz

3.2.3 Square Wave Generation with the help of 4093 Schmitt trigger

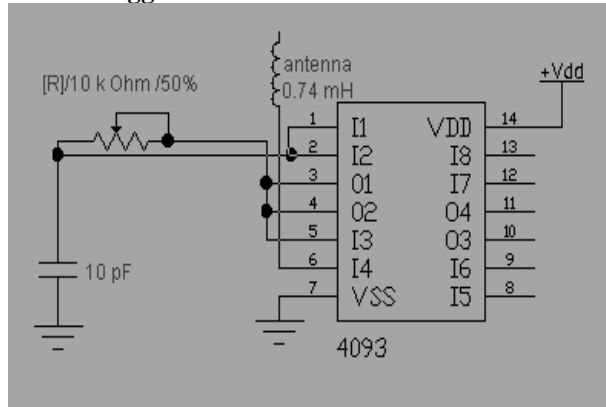

Fig.5. 4093 based Oscillator Circuit

At the pin no.3 the output wave shape of the signal obtained was saw tooth. The other data is given below (for Vdd=5V, Vss=0V)

Table7. 4093 based oscillator data in case of Saw-tooth wave

Resistor	Capacitor	V _{out}	I _{out(ac)}	I _{out(dc)}	Power μ watt	Frequency
9.1 K Ω	10 PF	1.2 V	.4 A	10.86 μ A	13.03 2	2.873649MHz
9.1 K Ω	1.0 PF	1.2 V	.4 μ A	10.86 μ A	13.03 2	2.80 MHz

At the pin no.6 the output obtained is of the Square wave shape. The other data is given below For Vdd=12V and Vss=0V

Table8. 4093 based Oscillator data square wave

Resistor	Capacitor	V _{out}	I _{out(A.C)}	Power nWatt	Frequency
9.1 K Ω	10 PF	25m V	1.2 μ A	30	2.6486 MHz
9.1 K Ω	2.25 PF	20m V	1.6 μ A	32	4.355 MHz
9.1 K Ω	1.5 PF	25m V	1.3 μ A	32.5	3.91 MHz
9.1 K Ω	1 PF	20 mV	2.0 μ A	40	4.03 Hz

4. CONCLUSION

The main objective of this research was the designing of low cost, durable, health and environment friendly RF circuits with the help of commercially available components in the Hall road market, Lahore. These circuits are reliable and can provide the cheaper and efficient solution for commercial and security issues. The Radio frequency Jammers can be used by military and law enforcement agencies in war or Peaceful situations.

In this research work the communication signals were jammed due to interference of specific frequency and the whole spectrum with the help of AM or FM Jamming circuit in the Laboratory environment. The oscillators were designed with discrete components and 'VCO' ICS. The designed Circuit jammed effectively in the range of 15 meters. AM and FM jamming signals were generated by using transistor 2N-3904, 74HC04 (NOT gate), 74HC00 (NAND gate), 4093 (Schmitt trigger NAND gate) and VCO IC NE-566.

Higher frequency $f > 100$ MHz was generated by frequency multiplier circuits. The range of frequencies, transmission power and jamming distance was improved with the change of hardware design.

The further developments can be achieved by improving the transmission and interference issues. The jamming circuits were very simple and cheaper. They were prepared by non-commercial, off the shelf components. These low cost jamming circuits can be installed in various places to avoid unwanted communications.

5. ACKNOWLEDGEMENT

This research work was done in the electronics lab, GC University, Lahore. Thanks for the nice cooperation and all the facilities provided by the GC University during the whole research work.

REFERENCES:

Boylestad, R., and L.(n.d.). Nashelsky (1992), *Electronic Devices and Circuits Theory*. 7th edition, Prentice Hall,Upper Saddle,New Jersey, columbus,ohio.

Chang, K. (2000) *RF and Microwave Wireless Systems*. New York: John wiley & Sons, Inc.

Chris, O'Connor. (2000) Develop a timeless voltage Controlled Oscillator. *Microwave & RF*, 105-110.

Dai, L. (1997)Low Phase Noise Voltage-Control led Oscillator.Project Report, Fall, 1-14

Dai, L., and R. Harjani, (2000) Low Noise Voltage-Controlled Oscillator. International *symposium* on low Power Electronics and Design 2000,ISLPED'00 Minnesota Univ., Minneapolis, MN, USA: IEEE. 29-294

Floyd, T. L (1997) Digital fundamentals. Prentice Hall,Upper Saddle,ninth Edition, New Jersey, columbus,ohio.

Floyd, T. L. (2012) Electronic Devices. New York: Prentice Hall,Upper Saddle, New jersey, columus, Ohio, Ninth Edition,.

- Frenzel, E. L. (2001) *Communication Electronics Principles and Applications*. New York: McGraw-Hill. Communication Electronics: Principles and Applications, (<http://www.datasheetcatalog.com/>, n.d.)
- Jacob, J. (2000) *Applications and Design with Analog Integrated Circuits*. New Jersey: Pearson Prentice Hall,.
- Lathi, P. B. (1998) *Modern Digital and Analog Communication Systems*. 3rd edition, New York: Oxford University Press,.
- Liao, Y. S. (1996) *Microwave Devices and Circuits*. 3rd edition, New Jersey: Prentice Hall.
- Schweber, W. (2002) *Electronic Communication Systems fourth Edition*. 3rd edition, New Jersey: Prentice Hall,.
- Stalling, W. (2000) *Wireless Communication and Networks*. New Jersey: Pearson Prentice Hall, 2nd edition,.
- Tomasi, W. (1998) *Electronic Communications Systems Fundamentals through advanced*. 3rd edition, New Jersey: Prentice Hall.
- Ulaby, F. T. (2006) *Fundamentals of Applied Electromagnetics*. 6th edition, Prentice Hall, .
- Wu, H., and A. Hajimiri. (2000) '10GHz CMOS Distributed Voltage Controlled Oscillator'. *CUSTOM Integrated Circuits Conference*, IEEE, 581-584.