



Prototyping and Stabilizing of Under-Actuated Remotely Operated Vehicle (ROV) using Fuzzy PID Control Algorithm

Sadiq Ur Rehman, Halar Mustafa, Huzaifa Bin Saleem

Department of Electrical Engineering, Hamdard University Karachi, Pakistan

sadiq.rehman@hamdard.edu.pk, halar.mustafa@hamdard.edu.pk, huzaifa.saleem1@gmail.com

Abstract: Under-water vehicle is unstable and non-linear. Structures in which the degree of freedom is greater than the number of actuators are very difficult to stabilize. In the case of the remotely operated vehicle (ROV) for underwater monitoring, position stabilization is a key issue. It has been seen that the design of the ROV structure with the ability to stabilize itself in terms of position and designing of a control algorithm for actuators that works along with the structure is not an easy task. In this paper, we present the modeling and control design of under-actuated unmanned underwater ROV to address the non-holonomic issues. The proposed ROV is energy-efficient, cost-effective, and has a fast response time, moreover, a novel hybrid Fuzzy-PID algorithm is developed to stabilize the dive control of under-actuated underwater tri-thruster ROV is also proposed and the simulation results confirm its authentication.

Keywords: Remotely Operated Vehicles; Unmanned Underwater Vehicles; PID; Fuzzy; Hybrid

I. INTRODUCTION

There are various numbers of Remotely Operated Vehicle (ROV) in the world which are used for different purposes. ROVs have considered steerable and sailable vehicle works underwater. By the use of these kinds of underwater vehicles, one can easily explore the sea, river, or lake without diving into the depths. This is an alternative to sea diving which has been done just to analyze the environment at the depths, instead of sending the human. These underwater vehicles are remotely operated by the user at a distance which could be the seashore, at the deck of the ship, at the island, etc. ROVs can be wireless or wired. In the case of wired ROVs, a bunch of cables is used for power and data transfer. These cables are connected with the controller placed in the ROV and the user gets the result in processed form. Some of the frequent use of ROVs include species surveying, inspection for oil and gas, an inspection of nuclear reactors, research analysis in science, deep-sea inspection for trash, etc.

It has been a challenge for researchers to design automatic underwater machines which should be simple, contains diving capabilities with rapid turning and reversing feature. In this paper, we presented the prototype model of under-actuated unmanned underwater remotely operated vehicle. The modeling and control design of the proposed model addresses the non-holonomic issue. Unlike ordinary ROVs, this prototype will consist of three main thrusters for motion in x and y-direction. A flap will attach to it by a servo motor to control yaw motion and to control the direction and turning. The proposed prototype is more efficient than other underwater ROVs because the stability will be provided by the structure itself. No power will be consumed by the ROV to stabilize itself in case of any external disturbance. Due to efficient design, the power

consumption was reduced by 50% as compared to quad thruster ROVs. Moreover, we provide an efficient algorithm for a control technique to stabilize the dive control of under-actuated ROV in water which is a hybrid technique based on Fuzzy based PID control.

II. LITERATURE REVIEW

ROVs attract military organizations, private companies, and civilian users. It was the year 1953 when F started doing work of the very first ROV [1] and hence it got finished as the United States (US) navy itself took interest in the development of these types of underwater vehicles which are cheap and small. US navy thinks that this project should take off to design a better model for the surveillance of the sea. It was the year 1961 when the US navy started researching more upgraded versions of ROV, however, at that time the ROVs were used for finding the remains of the warships in the ocean depths. When this project becomes successful, the US navy started to bring different types of ROVs with upgraded structures in the market. 20 ROVs were available in the year 1974, in the year 1982, the figure raised to 500, and in the year 1998 these number hits to 3000.

ROVs are one of the most complex types of diving robots or machines. Under-actuated structures are very advanced and are capable of performing vertical floating, diving, fast responsive, and can take sharp turns. The majority of the ROVs are depended upon gyro sensors and accelerometer systems to feedback the thruster so that they run in a specific controller-guided way to achieve stability [2]. To achieve this goal a multi-rotor or Unmanned Underwater remotely operated Vehicle (UUV) is the best available solution in which we can add a thruster for each degree of freedom to move the ROV in that way. Table 1 represents the advantage and disadvantages of different ROVs.

TABLE I. COMPARISON OF ROVS

Reference	Contribution	Pros	Cons	Algorithm PID or FUZZY
[2]	A proper control system has been applied on ROV but in simulation only	Provide good knowledge of PID and Fuzzy	Does not provide a method to merge these two systems in a single project	Both PID and FUZZY but not a Hybrid Fuzzy. (Both algorithms are discussed separately)
[3]	Box shape ROV with vision sensor and image processing	As it is autonomous it doesn't need any operator control vision sensor for targeting, it works on image processing.	They used a simple Arduino program and didn't use any control algorithm.	No special Control algorithm
[4]	Solution for Altitude and Position disturbance caused by waves	The method of position and altitude controlling is used for observing disturbance ROV. When ROV moves or is disturbed by tidal.	They are only considering Disturbance and not fixing it.	Only the PD controller
[5]	A new shape (Quad-rotor)	ROV can easily stabilize because each thruster can rotate 360o.	It contains 4 thrusters to control ROV in six directions. Which consumes more power.	No Fuzzy No PID But Robust sliding motion control
[6]	Biometric Punting with the combination of two video motion capture	They collect all Biometric types of ROV, each collecting different types of underwater data.	They did not work on hardware or software related to ROV.	Open and feedback loop control system
[7]	Structural analysis	They are tracking different objects and fishes underwater.	They are not avoiding obstacles during tracking.	No control algorithm defined, just mechanical analysis and modeling
[8]	Comparison of Fuzzy and PID in terms of ROV	Parameters of ROV such as velocity, depth, and balance angle are also displayed.	They are using 6 thrusters 2 for vertical and 4 for horizontal.	Comparative analysis of Fuzzy and PID.
[9]	Control system simulation	Two major fuzzy classes are used known as CFLC and AFLC.	They did not work on hardware related to ROV.	Only Fuzzy
[10]	Evaluation of future capabilities	They explain the history and working principles of ROV.	They did not work on hardware or software related to ROV.	Just theoretical analysis No hardware or software development of ROV
[11]	PSO Algorithm design and simulation for ROV	They detect capabilities to explore the effects of the robot with enhanced capabilities.	They did not work on hardware or software related to ROV. They just explain it.	No fuzzy or PID or F-PID But, PSO (Particle Swarm Optimization) algorithm
[12]	Target tracking for ROV	The machine is capable of traveling through the shortest possible path when the start and ending point is given and also manages to let itself free of collision with obstacles.	Computational cost is high, not very effective in path planning when the surveillance area is larger.	PID
[13]	Fuzzy controls with non-linear membership functions.	Ensure that every UUV can track a target.	They didn't use any algorithm for stabilizing and tracking.	Fuzzy
[14]	Launch and Recovery of ROV	Gives a good comparison between types of fuzzy.	Only fuzzy logic is covered and no productivity is done.	LARS Control Algorithm
[15]	Virtually realistic underwater simulation	Gives good ideas about the initial parameters.	No structural stability is discussed	Not defined

III. ROV DESIGN AND MODELLING

A lot of ROVs have been designed before as mentioned above, some proposed fuzzy logic algorithms [16] some proposed PID algorithms [17]. A lot of work has been done on robust theory as well but in this paper, we proposed the novel hybrid Fuzzy-PID algorithm to simulate Tri Thruster ROV to reduce the instability by the design of structure which stabilizes itself, save energy,

monitor the parameters in-depth, and shows the result on LCD, fast response time and auto direction control and keep itself in a stable position. To achieve this, the following structural diagram was considered (see Figure 1).

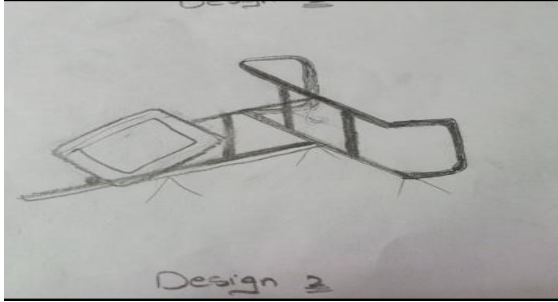

Figure 1. Proposed ROV structure

It was a tough task to design a structure that stabilizes itself, after 4 different types of design consideration, we created a narrow nose design, and it consists of a triangular-shaped structure with a diagonal nose providing the required stability. AutoCAD [18] is used to model the 3D version of the ROV structure. In AutoCAD realistic option is used which gives the provision to draw structure as realistic as possible so that after making a virtual structure one can identify the mistakes and finalize the errorless design (see Figure 2).

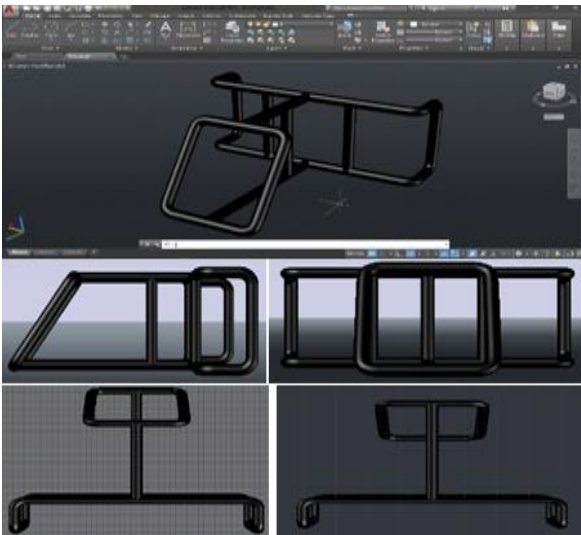

Figure 2. Proposed ROV structure

The key objective behind the development of the proposed ROV is cost-effectiveness. ROV structure is designed in such a way that it stabilizes itself in water without any use of force (thruster). We balance downward and upward forces by making out the structure of greater density from the bottom side and lighter density from the upper side. This technique was given by Archimedes principle [19] as shown in Equation (1),

$$F_b = \rho g V \quad (1)$$

Where F_b denotes the force applied by the fluid onto the submerged object, ρ is defined as the density of the fluid, V is defined as the volume of the fluid displaced by the body, and "g" is the acceleration due to the gravity of

earth. So, in the case where objects of equal masses are completely submerged into water or any other liquid, objects having greater volume will possess greater buoyancy.

Archimedes principle is used to cancel out the net weight of the proposed ROV in water. To keep ROV denser from the lower side, some weights (like glue) inside the lower frame are placed. To keep the ROV in a stable position, buoyance foam is placed on the upper side of the prototype which can be seen in Figure 3. The amount of this foam is placed in such a way that the upward thrust cancels out the downward weight. It has also been tested that there was no chance of the ROV to flip itself. If any hurdle or wave flipped the ROV, the upward and downward force main the stability of the ROV.



Figure 3. ROV physical structure using PVC & Stabilization using Archimedes Principle

After finalization of the structure, thrusters are mounted on a structure and tested manually on the frame using a potentiometer and an Arduino UNO [20] (see Figure 4). It has been observed that the thrusters were working and responding quickly.

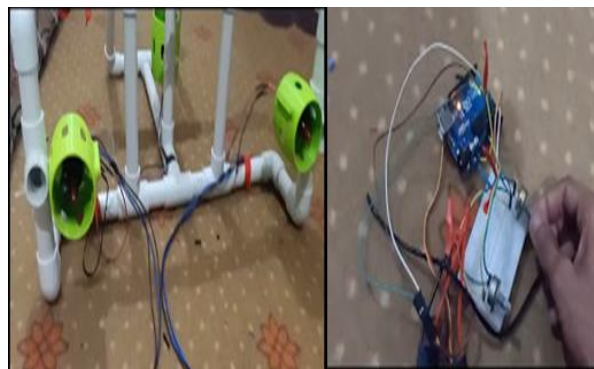

Figure 4. Mounting the thrusters and manual testing

Underwater testing of the structure along with the thrusters was also done and can be seen in Figure 5.

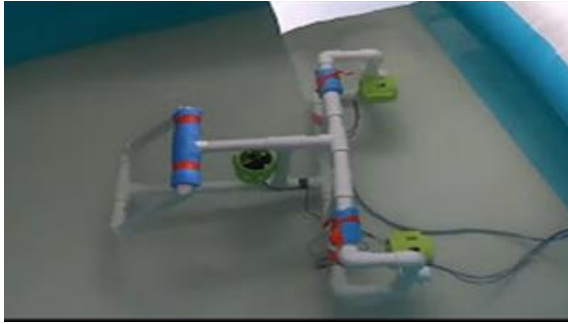

Figure 5. Testing thrusters underwater

IV. SYSTEM BLOCK DIAGRAM AND WORKING

Four sensors are used in this proposed ROV which are namely pressure sensor, voltage sensor, temperature sensor, and vision sensor respectively. The reading from all the sensors is processed in Arduino MEGA which transfers the communication in the drive unit as well as a remote controller. The drive unit consists of relay modules which are used to switch between the two phases to reverse the direction of ROV, along with the three Electronic Speed Controller (ESC) to run three Brushless DC (BLDC) motors, three 2N2222 transistors are also used as a switch along with each pair of relays to provide the necessary current so that the relay switch properly (see Figure 6).

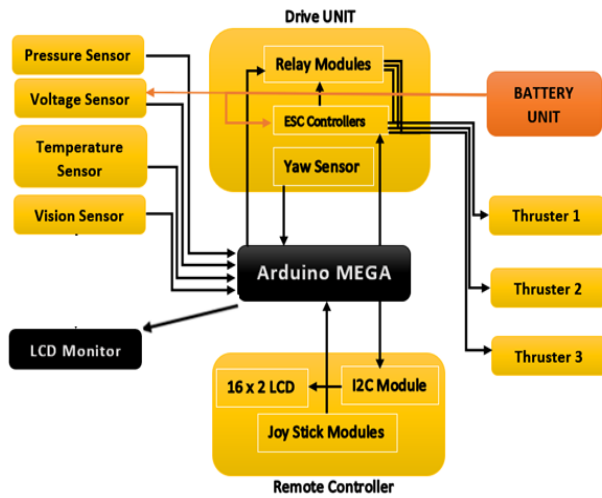

Figure 6. System Block Diagram

This is because the digital pin of Arduino is unable to provide sufficient power to the relay's mechanical shaft attached to the coil. The power to the transistor is coming from the ESC 5v output because the ESC used contains a battery eliminator circuit along with 3 phase output, which also gives out 5v DC to power up other components. These other components include the three sensors, the joystick module, and the LCD placed on the

front of the remote which display the values from the sensor. The Drive unit also consists of a QMC58831 compass as a yaw sensor which detects the yaw movement, feedbacks it to the controller, and keeps the ROV in a stable position.

A. Development of Relay Modules for BLDC

We create a logic with relays to change the direction of our thrusters. To change the rotation of the BLDC motor, two wires appear to be the +ve and -ve DC rails. The inverter circuit comes after the DC power section. So, you need first to find the inverter section of your BLDC driver and then find the three-phase wires. After that, interchange any two phases to change the direction of the motor. We design a relay module to interchange 2 wires to reverse the direction of the motor. The circuit diagram of the 1 phase shift system can be seen in Figure 7, we have used three of them as we are working on 3 thrusters (see Figure 8).

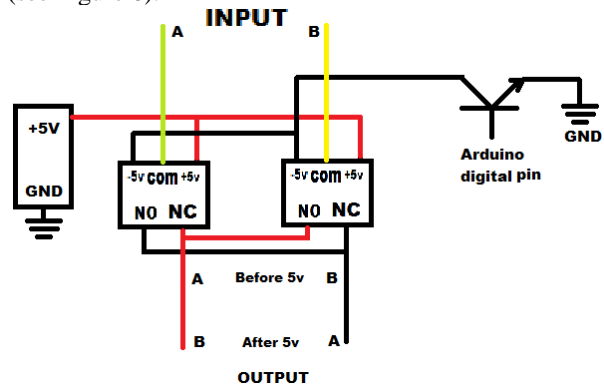

Figure 7. Relay Module Circuit Diagram

If the input of the module is 0 volts then the motor rotates in a clockwise direction, input wire A remains A wire at the output, and input wire B remains B wire at the output. But if we give 5 volts to the module then wire A and B interchange with each other, switching the two of three phases on which the BLDC motor is running producing the rotating magnetic field in opposite direction, thus changing the direction of our underwater BLDC thrusters. We have used the 10 AMP mechanical relay as we want our prototype as cheap as possible, it was also possible for us to use JFET or MOSFET to create an H-bridge which is also used to change the direction of motors by interchanging the two input wires

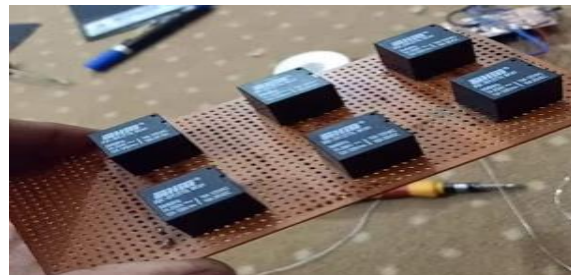

Figure 8. Figure 8. BLDC phase reversals module

B. Direction Control

For right and left direction control, we use a joystick module. A joystick module (see Figure 9) is a variable resistor that runs on five volts and varies its output voltage when the lever is pushed up or down.



Figure 9. The Remote/Joystick Controller

We took the analog output from the joystick module and map it in the Arduino according to the required values, as the values got mapped from 0-1024 to -180 to 180. Pulse width Modulation (PWM) variable of ESC command is replaced with the joystick analog output so that by using that module one can easily vary the duty cycle of the PWM generated thus varying the speed of thrusters. When we want to move ROV in the left or right direction, start submission in the programming of the module of one thruster so the speed of one thruster will slow down, and due to the difference of speed in between two thruster, the ROV turn left or right as required. When we move the second joystick module on the left side, it is mapped in Arduino in such a way that its values got canceled out by the values of the first module to send a zero output to one thruster so that it gets slow or stopped depending on the dragging of module lever, once the thruster stops the other still runs ended up turning the ROV in one direction.

By using this method, we have successfully changed the direction of our ROV in left and right turns. For the front and back-work movement, when joystick resistance exceeds a threshold value, the Arduino sends on command to the relay module which switches both relays hence changing the phase thus thrusters stop and start to rotate in another direction when the joystick is left free, it jumps back to its original position decreasing the mapped value of resistance, when the value drops below threshold Arduino sends an off command to module hence the relays become un-switched reversing the phase to the original position thus thruster start to rotate at default direction. In this way, we can forward and backward the proposed ROV. 2 x joystick modules, I2C module, LCD, and Cat 6 ethernet cable connection for communication are used for the remote control that will be used for controlling ROV. For the controlling box, Arduino mega, relay modules, ESC controllers, YAW sensor, and connectors are used. This controlling box (waterproof) is placed on the frame of ROV and can be seen in Figure 10.



Figure 10. Waterproof controlling box for ROV

The LCD (placed on the remote control) shows whether the ROV is "STOPPED", moving "FORWARD", "REVERSE", "STABLE" and turning "LEFT" and "RIGHT". The numbers displayed at the lower right corner of LCD are the direction of ROV which is North, East, West, and South, mapped from 0-360 degrees, by these numbers ROV tends to stabilize itself keeping it in a stable heading position. The final structure diagram of ROV along with all the electrical components mounted on it can be seen in Figure 11.



Figure 11. Prototype ROV

C. Implementation of PID in MATLAB

Simulation of Fuzzy Logic PID hybrid control scheme on proposed ROV is a primary goal which was achieved using the dynamic equation (written blow) of motions derived from [21]. Before going for PID we first simulate and control the system just in PID and after successful implementation of PID, we extend it to the implementation of Fuzzy Based PID. The first step here was to insert the dynamic equation into the Simulink using matrices. There was a total of three matrices which are namely M, D, and C matrices. The first matrix is targeting the dynamics responsible for the lateral movement in the x-direction both forward and reverse. supported by the different constants taken is as a delta to provide the system a mathematical value of environments faced by the original system in the form of body friction, water pressure, the viscosity of the liquid, small waves and jerks inside the water environments, thruster vibration, speed impacts, drag forced on every side of proposed ROV and all other constants faced by the ROV.

The second matrix is responsible for the up and down movement in the y-direction and the third one is

responsible for the left and right directions (see Figure 12). Now the second step is row selection and PID implementation. Full PID implementation on the very first matrix can be seen in Figure 13, after the columns selection the data is converted in a viewable form and transferred further for the graphical representation on the scope using mux, but the feedback has been taken by the

PID controller and feed again into adder after the column selection to continue telling the system to achieve required angle. The second and third matrix outcomes and their PID implementation can be seen in Figure 14, for the third matrix the initial condition was set as zero and the required outcome is set as 20 degrees.

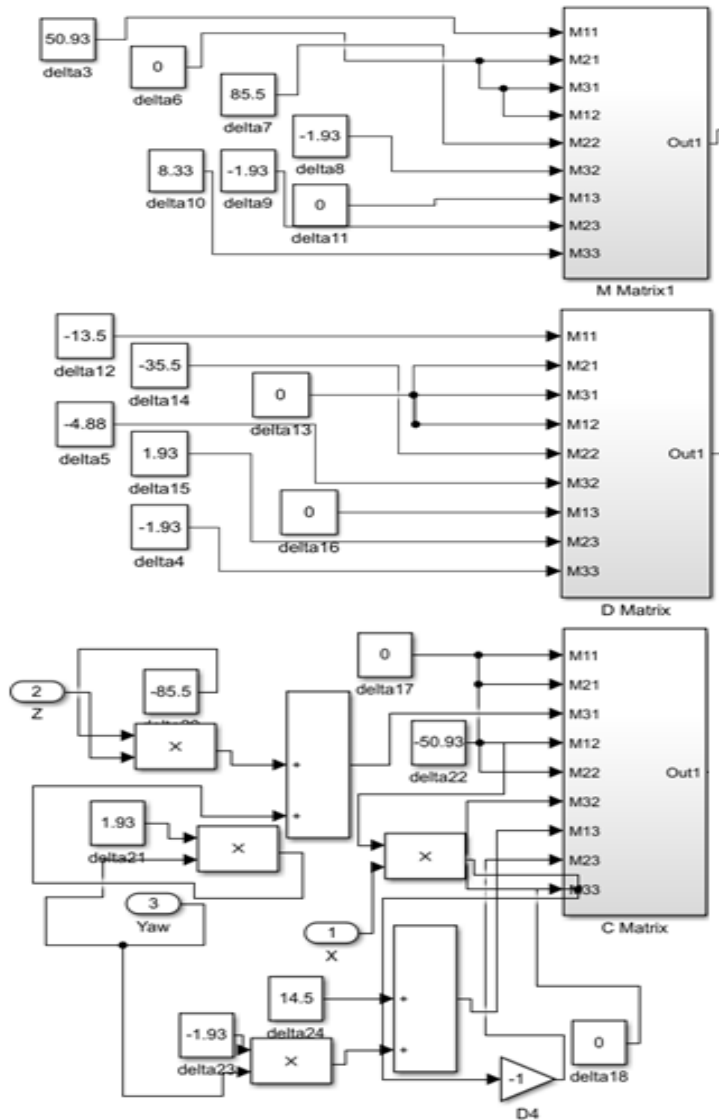

Figure 12. Defining the Dynamic equation in matrix form in MATLAB [22]

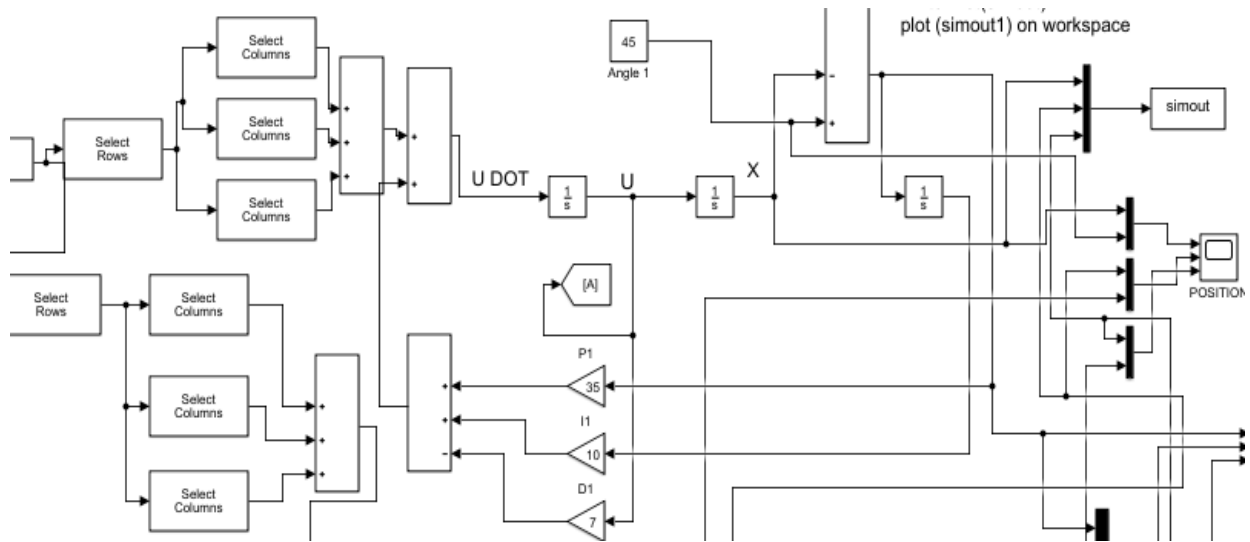

Figure 13. PID Blocks Implementation of the first matrix

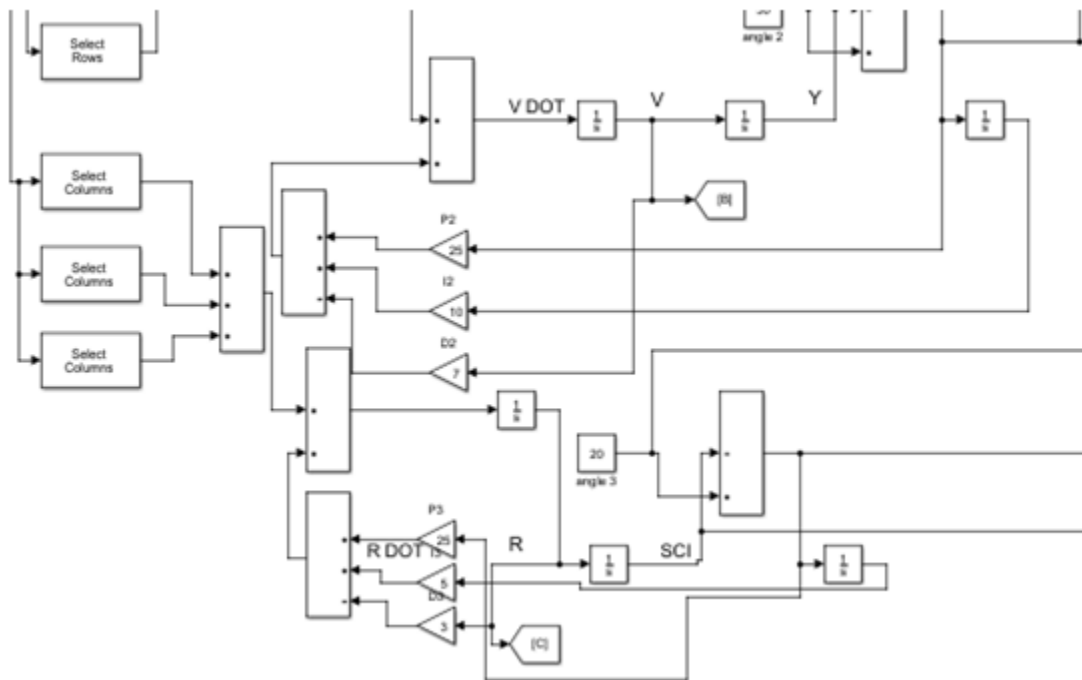

Figure 14. PID Blocks Implementation of last two matrixes

D. The Fuzzy PID Implementation

After successful implementation of the PID, implementation of the Fuzzy control algorithm along with the PID control algorithm was performed by doing the adjustment of fuzzy along with the PID control algorithm. Using the same dynamics and same dynamic equation, adjustment in the previous simulation of PID was performed which helps in the implementation of fuzzy logic in it. To make simulation easy and precise, the interface was altered. Different windows were used for different controllers along with the separate field of work for dynamics and interconnecting all the boxes and windows. Complete simulation of F-PID can be seen in Figure 15. The dynamics block has all the dynamics fed into it along with all rows and column selection ready to feed into the controller through the chain of integrators 1, 2, and 3. Three different control boxes have been

selected for better understanding. All of the boxes are interconnected and work the same as PID.

The fuzzy control box is now connected to the controller boxes to simulate a hybrid control algorithm of Fuzzy and PID, also called F-PID. The control boxes are almost identical with each other, there is just a difference of some PID tuning values, while the fuzzy rules remain the same. Fuzzy rules are a set of boundaries provided to the system or fuzzy logic controller to bound it to regulate between a specific set of instructions. This is a chain of integrator where reference and desired angles of motion can be selected which the controller achieve. The control box contains the reference input from the chain of integrators and feedback to the chain of the integrator. Setting up the fuzzy logic controller, the fuzzy block configuration, and defining the fuzzy rules can be seen in Figure 16.

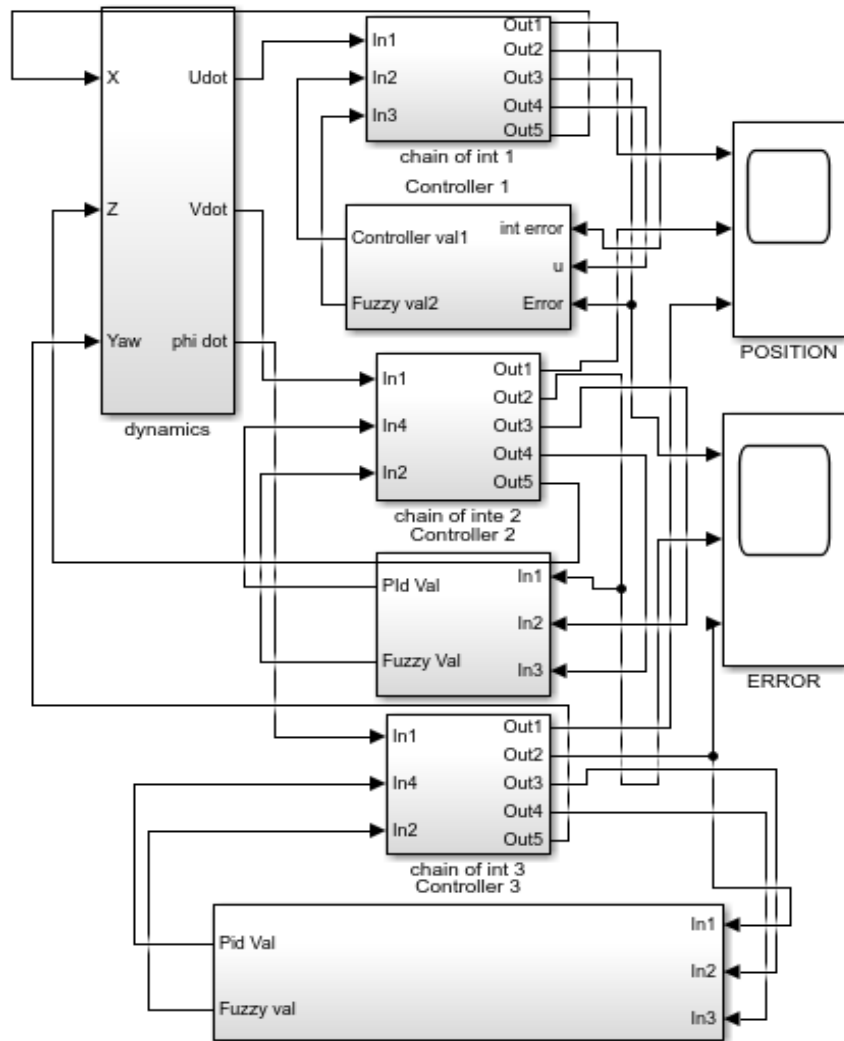

Figure 15. Simulation block of F-PID

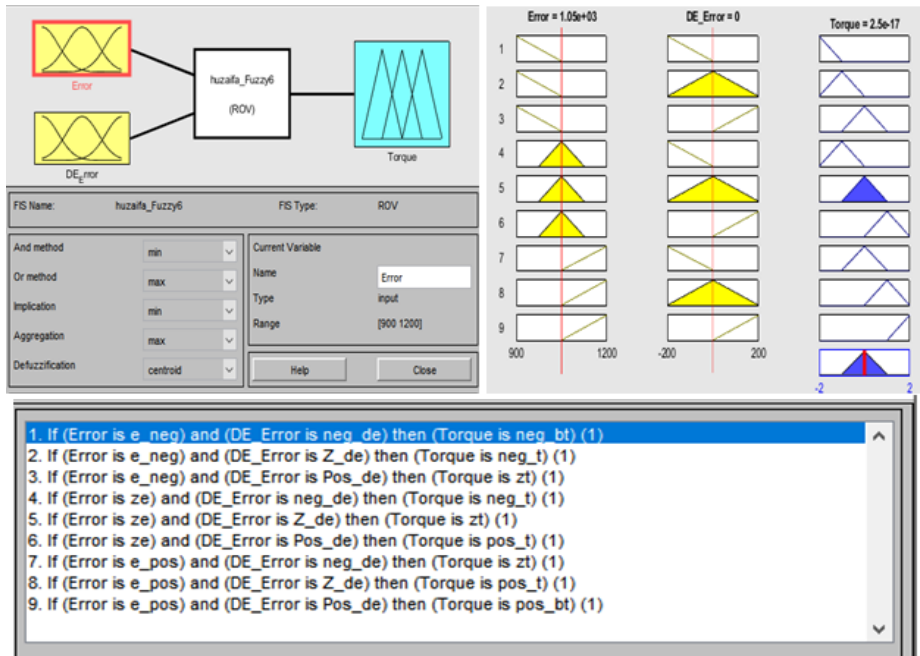

Figure 16. Fuzzy block configuration and defining the fuzzy rules

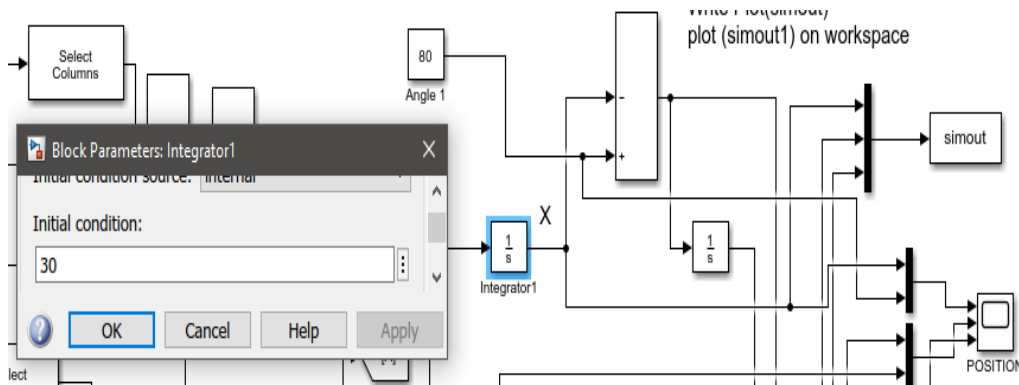

Figure 17. PID Condition Insertion

V. RESULT AND TESTING

Recursive testing has been done on the proposed ROV model to record the result which satisfied the system performance and achieved the desired goal.

A. PID Results

In integrator 1 the initial condition has been selected as 30 degrees and the required angle is 80 as can be seen in Figure 17. The x-axis motion of the ROV is stabilized and the output graph can be found in Figure 18.

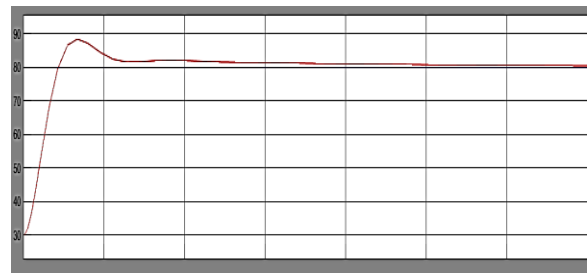

Figure 18. The Pitch Movement PID graph

The PID achieves the required angle in about 1.3 seconds. The same thing happens for the second matrix but with different parameters. For the second matrix, or the second position, the initial condition is fixed to zero

and the desired output is set as 30, after running the simulation the second movement of the y axis shown by the outcome graph can be seen in Figure 19.

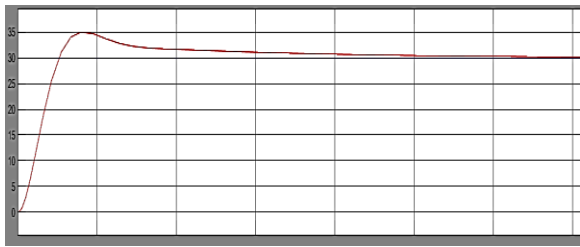

Figure 19. The Roll movement PID graph

The PID achieves the results in about 1.6 seconds. Now for the third dimension after setting the initial and final condition by following the same procedure as of the first matrix, the third graph shows the Yaw motion as stabilization which can be seen in Figure 20.

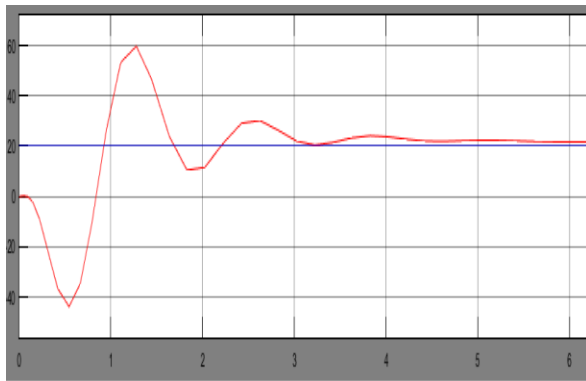

Figure 20. The YAW Movement PID Graph

Here the redline started from zero and ends up stabilizing the system after 2.5 seconds, the difference in time is due to the difference of PID gain for these positions, the stabilizing time can be reduced according to the requirement by tuning the PID again. The simout function was used to show the output results in one place which can be found in Figure 21.

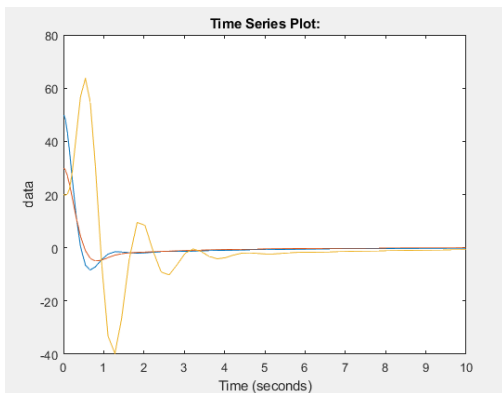

Figure 21. SIMOUT Function Graph

B. The Hybrid FUZZY Results

After compiling and running the simulation, the F-PID starts to work and outputs the desired outcome can be seen in Figure 22.

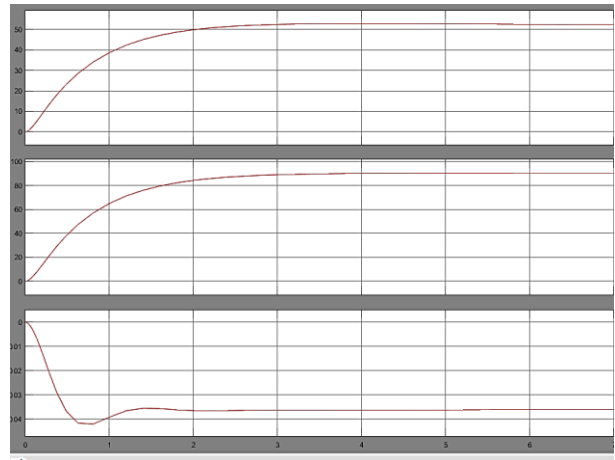

Figure 22. Fuzzy PID all three angles graph

The F-PID starts to work and from the initial point the controller starts from zero and achieve the desired result of 53 degrees in the first graph, as reference was set to 53 degrees, in the second slot the reference was set to 90 in controller 2, so it achieves the required 90 degrees in 2.2 seconds and for the third one it achieves the desired value 1.5 seconds, further tuning of the PID values can increase or decrease the overshoots, response time and harmonics. In this, we first implement the PID algorithm and then achieve our objectives by the implementation of the F-PID algorithm on a marine vehicle (ROV).

C. Testing in Water

The ROV's motion and stability were tested in a small swimming pool which can be seen in Figure 23 and the result shows that the ROV was able to move in desired degrees of freedom and respond to the commands given by the remote very quickly.



Figure 23. Testing underwater and camera results on the laptop

VI. CONCLUSION AND FUTURE WORK

Unlike ordinary ROVs, this prototype consists of 3 main thrusters for motion, 2 in x and 1 in the y-direction. For yaw motion, 2 thrusters are connected in x-direction and

control movement by varying speed. This prototype is more efficient than others because the stability was provided by the structure itself. No power will be consumed by the ROV to stabilize itself in case of any external disturbance. Due to efficient design, the power consumption was reduced by 50% as compared to quad thruster ROVs.

This prototype has a lot of potential and room for improvement some of the possible further works can be on the structure. The prototype is made up of Poly Vinyl Chloride (PVC Pipes), they can be replaced by a stiff carbon fiber structure that will be stronger and lighter in weight. Lightweight batteries (Li-Po battery cells) can also be used which can be placed within the structure. Furthermore, the mechanical relay modules were used to change the direction of rotation of BLDC thrusters, development of phase reversal modules using MOSFETs and JFETs by making a combination of H-bridge is suggested which will be more reliable than the mechanical relay. Moreover, a more advance, ultrasonic wave method can be used to make the ROV wireless or partially wireless with a receiver on the surface of the water.

REFERENCES

- [1] Keerthi Kumar, N. "Overview of Remotely Operated Vehicles." *Turkish Journal of Computer and Mathematics Education (TURCOMAT)* 12, no. 13 (2021): 2297-2305.
- [2] A.M. Abdullah, N.I. Zakaria, K.A.A. Jalil, N. Othman, W.M. Dahalan, H. Hamid, M.F. Ghani, A.Y.I. bin Mohd Haidir, M.I.M. Kamro , "Review of the control system for an unmanned underwater remotely operated vehicle", *Engineering applications for new materials and technologies*, 85, Springer, Switzerland: 609-631, (2018).
- [3] L.W.L. Alexander, K. Isa, H.A. Kadir, R. Ambar, "Development of an Autonomous Underwater Vehicle for Target Acquisition", *Proceedings of the 10th National Technical Seminar on Underwater System Technology*, Singapore, pp-65-78, 2019.
- [4] Sakiyama, N. Motoi, "Position and attitude control method using disturbance observer for station keeping in the underwater vehicle", *IECON 2018-44th Annual Conference of the IEEE Industrial Electronics Society, USA*, pp-5469-5474, 2018.
- [5] J. Bian, J. Xiang, "QUUV: A quadrotor-like unmanned underwater vehicle with thrusts configured as X shape", *Applied Ocean Research*, 78: 201-211, 2018.
- [6] M. Perkins, "Development and Modeling of a Biomimetic Punting Unmanned Underwater Vehicle", *MSc. Thesis, University of Rhode Island, Rhode Island*, pp-17-41, 2018.
- [7] Z. Guan, D. Zhang, M. Lin, J. Li, "Mechanical analysis of remotely operated vehicle", *4th International Conference on Control, Automation and Robotics (ICCAR)*, Auckland, pp-446-450, 2018.
- [8] X. Xiang, C. Yu, L. Lapierre, J. Zhang, Q. Zhang, "Survey on fuzzy-logic-based guidance and control of marine surface vehicles and underwater vehicles", *International Journal of Fuzzy Systems*, 20(2): pp-572-586, 2018.
- [9] Zhiguang, Z. Dong, M. Renlong, J. Ru, and L. Mingxing, "Control system design of remotely operated vehicle", *15th International Conference on Ubiquitous Robots (UR)*, Honolulu, pp-857-862, 2018.
- [10] Wong, "Evaluation of Future Unmanned Underwater Vehicle Capabilities in An Automated Computer-Aided Wargame", *Ph.D. Thesis, Naval Postgraduate School, California*, 19-37, 2018.
- [11] J. Xu, H. Gu, H. Liang, "Path Planning for Unmanned Underwater Vehicle Based on Improved Particle Swarm Optimization Method", *International Journal of Online Engineering*, 14(12): pp-137-149, 2018.
- [12] Z. Yan, X. Liu, J. Zhou, D. Wu, "Coordinated target tracking strategy for multiple unmanned underwater vehicles with time delays", *IEEE Access*, 6: 10348-10357, 2018.
- [13] T.V. Pham, A.G. Shpektorov, "Comparative analysis of fuzzy regulators for controlling the movement of an autonomous underwater vehicle", *IEEE Conference of Russian Young Researchers in Electrical and Electronic Engineering (EIConRus)*, Moscow, 954-957, 2018.
- [14] E.I Sarda, M.R. Dhanak, "Launch and recovery of an autonomous underwater vehicle from a station-keeping unmanned surface vehicle", *IEEE Journal of Oceanic Engineering*, 44(2): 290-299, 2018
- [15] O. Ganoni, R. Mukundan, R. Green, "A Generalized Simulation Framework for Tethered Remotely Operated Vehicles in Realistic Underwater Environments", *Drones*, 3(1): 1-34, 2019
- [16] Cheng, Chen, Benying Liu, Feihu Song, Jianjun Jiang, Zhenfeng Li, Chunfang Song, Jing Li, Guangyuan Jin, and Jincheng Wu. "An adaptive fuzzy logic control of green tea fixation process based on image processing technology." *Biosystems Engineering* 215 (2022): 1-20.
- [17] Liu, Wei-Ling, Ping Liu, Xin Wang, Li-Chao Niu, Wei Zhou, and Yan-Jun Xiao. "High-speed loom brake system controlled by fuzzy PID algorithm based on cloud platform." *Journal of Intelligent & Fuzzy Systems Preprint*: 1-17.
- [18] T. Juraev, "Computer modeling the moldboards' surface in AutoCAD system", *In IOP Conference Series: Materials Science and Engineering*, 883(1): 1-10, 2020.
- [19] Paul, Surinder, Arun Kumar, and Arvind Kumar. "Synthesis and Characterization of La0.70Ca0.30MnO3 System for Solid Oxide Fuel Cell Applications." *In IOP Conference Series: Materials Science and Engineering*, vol. 1225, no. 1, p. 012054. IOP Publishing, 2022.
- [20] Rehman, Sadiq Ur, Shariq Ahmed Khan, Iqbal Uddin Khan, Halar Mustafa, and Muhammad Ahsan Shaikh. "Interactive Smart Writing Technology (ISWT)." *University of Sindh Journal of Information and Communication Technology* 4, no. 1 (2020): 1-8
- [21] T.I. Fossen, "Guidance and control of ocean vehicles", *Ph.D. Thesis, University of Trondheim, Norway*, 93-104, 1999.
- [22] Rehman, Aqeel Ur, Sadiq Ur Rehman, Zahid Hussain Babar, Muhammad Kashif Qadeer, and Faraz Ali Seelro. "Offline Signature Recognition and Verification System Using Artificial Neural Network." *University of Sindh Journal of Information and Communication Technology* 2, no. 1 (2018): 73-80